



SJ66T **TELESCOPIC BOOM LIFT**

Skyjack's robust and reliable SJ66T boom offers the lowest life cycle costs, proven reliability, and ease of serviceability. Superior terrainability is obtained utilizing Skyjack's axle based 4WD system offering unsurpassed traction and terrainability; using a 'No Spin' differential on the rear axle and limited slip differential on the front oscillating axle. Other competitive advantages include an innovative and intuitive direction sensing drive and steer control system which ensures the boom lift will always drive and steer with respect to the operator rather than the orientation of the chassis.

Skyjack's standard colour coded and numbered wiring system, along with proven relay based controls, complete a well rounded package of superior, proven, operating characteristics.



SKYJACK

TELESCOPIC BOOM LIFT

SPECIFICATIONS

SJ66T

AS/NZS 1418.10:2011

Work Height	22.12 m
Platform Height	20.12 m
Horizontal Reach	17.37 m
Platform Size	0.91 m x 2.44 m
Stowed Width	2.44 m
Tailswing	1.19 m
Stowed Height	2.57 m
Stowed Length	10.34 m
Wheelbase	2.44 m
Ground Clearance	0.41 m
Platform Rotation	180°
Jib Length	1.52 m
Jib Range +/-	63° / 66°
Weight	13110 kg
Gradeability - 4WD	50%
Turning Radius (Inside) - 4WD	2.82 m
Turning Radius (Outside) - 4WD	5.05 m
Axle Oscillation	0.25 m
Drive Speed (Stowed)	7.2 km/h
Drive Speed (Raised)	0.8 km/h
Capacity	227 kg
Maximum # of Persons	2

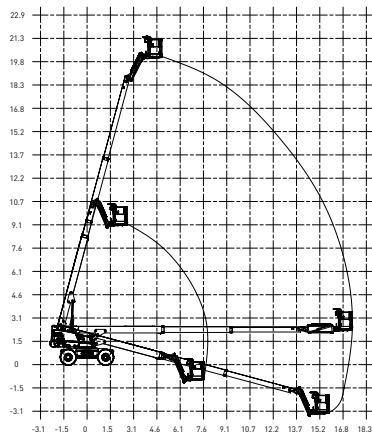

STANDARD FEATURES

- Axle based 4WD system
- "Detroit Locker" type rear differential and limited slip front differential
- Oscillating axle
- Drivable at full height
- 50% gradeability
- 65 hp Deutz diesel engine
- Swing out engine tray
- Swing up cowlings
- Modular platform railing system
- Spring hinged gate
- Wiring for AC outlet on platform
- Direction sensing drive and steer controls
- Proportional controls
- Relay based control system
- Colour coded and numbered wiring
- 360° continuous turret rotation
- Hourmeter
- Operator horn
- All motion alarm
- Overload sensing system
- Tie down/lifting lugs
- Wet disc SAHR brakes (front and rear axle)
- 15 x 19.5 grip lug foam-filled tyres

OPTIONS†

- Cold weather start kit
(Includes cold start engine oil, battery blanket, and hydraulic tank heater)
- Diesel scrubber
- Hydraulic oil cooler
- Flashing light
- 1/2" airline to platform
- 2WD

† Capacities, and machine weights may differ when options are added

Skyjack Australia Pty Ltd
4 Coates Place
Wetherill Park
New South Wales, 2164
Tel: +61 (0) 2878 63200
Fax: +61 (0) 2878 63222
Email: jcranmer@skyjack.com

www.skyjack.com



SKYJACK™

This brochure is for illustrative purpose only and based on the latest information at the time of printing. Skyjack Inc. reserves the right to make changes at any time, without notice, to specifications, standard and optional equipment. Consult the Operating Maintenance and Parts Manuals for proper procedures. AS marked platforms are in conformance to Standard AS/NZS 1418.10:2011.

AU/NZ/04/2013