

KANGA CUSTOM BUILT TRAILER SYSTEMS

FRANKS



1.8T Single

3.5T Tandem deluxe

2.0T & 3.5T Tandem

The inventors of the world's first 'stand-on' skid steer loader introduce Custom Built Trailer Systems. A complete 'turn-key' business solution, a Kanga Trailer offers the ultimate in portability, convenience and profit potential for a Kanga Loader-based business. Manufactured to the same exacting engineering standards as each and every Kanga Loader, a Kanga Custom Built trailer will give you many years of reliable, trouble-free service.

The intent of this document is to identify standard configurations of the KID and Kanga trailers, this is a guide only and common sense prevails, all trailers have weight limitations as shown on the identification tag on the draw bar. Due to a policy of on-going research and development, Kanga reserves the right to change equipment specifications without prior notice. Please contact your Kanga dealer for further information.



ADVANCED ENGINEERING TURNING HARD WORK INTO EASY BUSINESS

1.8T Single

Specifications

Part No	OK90404
Attachment Mounts	KID/Kanga
Tare	435kg
Axle Capacity	1850kg
Max Load	1415kg
Brakes	Electric
Tyres	195x14x8ply
Rims	14x6
Floor	Checker Plate
Ramps	2 x ramps
Spare Wheel	14x6

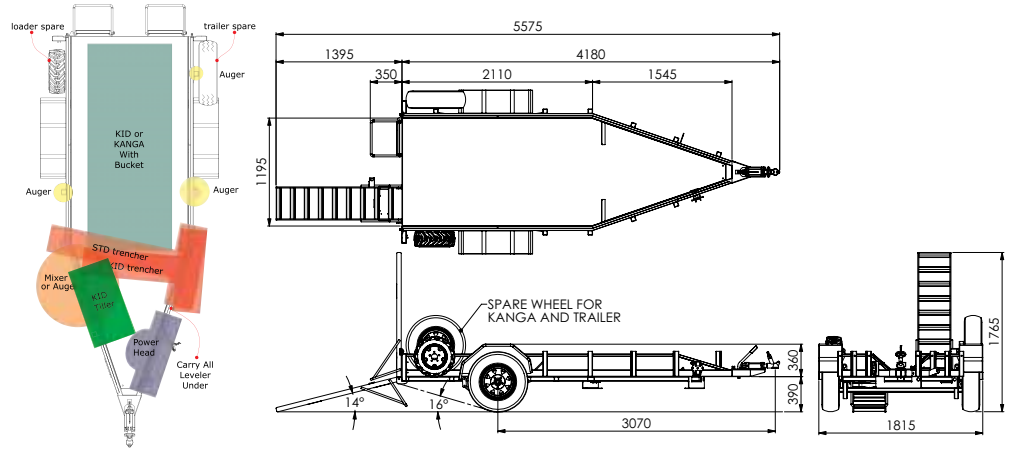

2.0T & 3.5T Tandem

Specifications

Model	2T Tandem	3.5T Tandem
Part No	OK90461	OK90466
Attachment Mounts	KID/Kanga	KID/Kanga
Tare	645kg	688kg
Axle Capacity	2000kg	3500kg
Max Load	1355kg	2812kg
Brakes	Electric 2 wheel	Electric 4 wheel Plus Breakaway
Tyres	195x14x8ply	195x14x8ply
Rims	14x6	14x6
Floor	Checker Plate	Checker Plate
Ramps	2 x ramps	2 x ramps
Spare Wheel	14x6	14x6

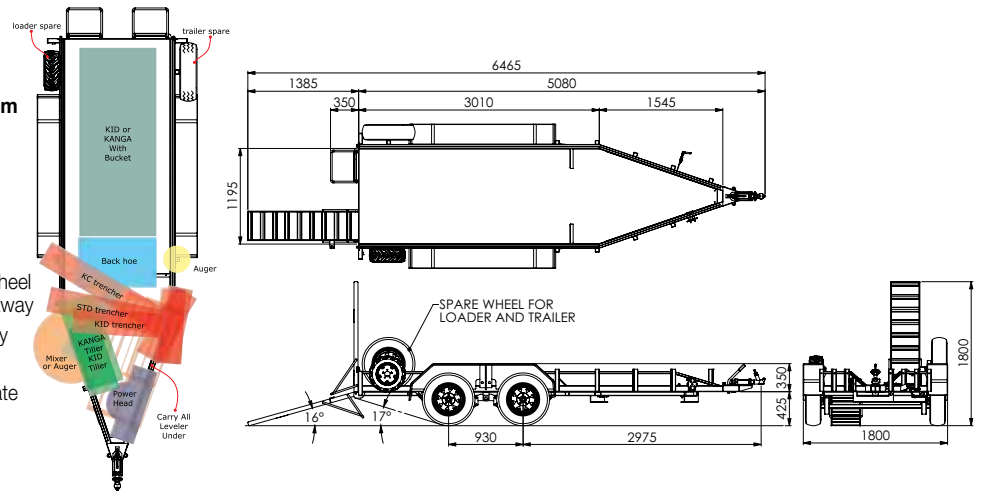

3.5T Tandem Deluxe

Enclosed Sides. Lockable Toolboxes.

Specifications

Part No	OK90309
Attachment Mounts	Kanga
Tare	900kg
Axle Capacity	3500kg
Max Load	2600kg
Brakes	Electric 4 Wheel Plus Breakaway
Tyres	195x14x8ply
Rims	14x6
Floor	Checker Plate
Ramps	Single ramp
Spare Wheel	14x6
Tool Boxes	2 (inc Padlocks)

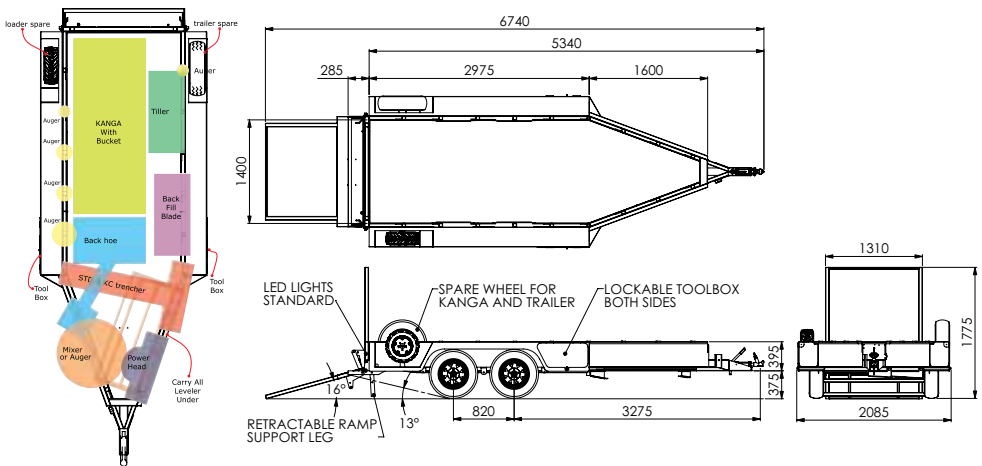

KID or KANGA with Bucket	STD Trencher 2.0T & 3.5T Tandem - cannot be used when carrying Kanga tiller unless moved to KC trencher position	KID Tiller Cannot be used when carrying Mixer bowl/Auger or Backhoe	Back Fill Blade
KANGA with Bucket	KANGA Power Head	KANGA Tiller 2.0T & 3.5T Tandem - Cannot be used when carrying Mixer bowl /Auger, Backhoe or STD Trencher	
Back Hoe 2.0T & 3.5T Tandem - cannot be used when carrying KC trencher, Mixer bowl/Auger or Tillers	Augers Can be positioned anywhere there is an available location, without interference	KID Carryall leveler	
KC Trencher 2.0T & 3.5T Tandem - cannot be used when carrying Backhoe, Standard trencher can take this position with KC trencher mounts	Mixer or Auger Cannot be used with Back Hoe or Tillers	KANGA Carryall leveler	

Plug options

(Vic, SA, Tas, NT.) **7 PIN LARGE ROUND PART # L190491**

(Qld, WA.) **7 PIN SMALL ROUND PART # L190492**

(NSW, ACT.) **7 PIN FLAT PART # L190493**

Australian designed, Australian made, Australian owned. For the complete range of Kanga Equipment, visit www.kanga-loader.com

For further information or details of your nearest Kanga dealer
Phone **1800 243 643** or email: sales@kanga-loader.com

AUSTRALIA: Brisbane • Gold Coast • Sydney • Canberra • Melbourne • Adelaide • Perth
NEW ZEALAND • UNITED KINGDOM • USA • SOUTH AFRICA • UAE



ADVANCED ENGINEERING TURNING HARD WORK INTO EASY BUSINESS