

SJ12/16

VERTICAL MASTS



STANDARD FEATURES

- Drivable at full height with platform retracted
- Variable speed, front two wheel hydraulic drive
- 90° Steering (zero inside turning radius)
- Dual holding brakes
- Shroud style, impact resistant composite control box
- Proportional controls for drive and lift functions
- 0.41 m Traversing platform
- 24V DC Power source
- Low voltage battery protection
- 30% Gradeability
- Solid rubber, non-marking tyres
- Pothole protection system
- Wiring for AC outlet at platform
- 12.5 m/s Wind rating up to 3.65 m
- Tilt alarm with drive & lift cut-out
- All motion audible alarm
- Lanyard attachment points
- Operator horn
- Lift rings/tie downs
- Full height spring hinged entry gate
- SKYCODED™ Colour coded and numbered wiring system
- Telematics ready
- Relay-based control system
- Dual flashing lights
- Tilt sensor (3.0° x 1.5°)

OPTIONS

- Light duty pipe rack
- Tool tray
- Florescent tube carrier
- AGM Batteries
- Saloon gate
- Bio Oil
- Secondary Guarding Lift Enable (SGLE)
- ELEVATE telematics
- ELEVATE Battery Management System (BMS)*

† Standard lead times may be increased when optional equipment is added, consult factory.

‡ Capacities and machine weights may differ when options are added.

* Only available with ELEVATE telematics

SJ12/16 VERTICAL MASTS

Dimensions	SJ12	SJ16
A Work Height	5.65 m	6.75 m
B Raised Platform Height	3.65 m	4.75 m
C Lowered Platform Height	0.46 m	0.46 m
D Overall Width	0.78 m	0.78 m
E Overall Length	1.40 m	1.40 m
F Stowed Height	1.78 m	1.78 m
G Platform Width (Inside Dimension)	0.69 m	0.69 m
H Platform Length (Inside Dimension)	0.86 m	0.86 m
Specifications	SJ12	SJ16
Ground Clearance (Stowed)	5.33 cm	5.33 cm
Ground Clearance (Raised)	1.60 cm	1.60 cm
Wheelbase	1.07 m	1.07 m
Weight	863 kg	980 kg
Gradeability	30%	30%
Turning Radius (Inside)	0	0
Turning Radius (Outside)	1.40 m	1.40 m
Lift Time (With Rated Load)	14 sec	21 sec
Lower time (With Rated Load)	15 sec	18 sec
Drive Speed (Stowed)	4.0 km/h	4.0 km/h
Drive Speed (Raised)	0.8 km/h	0.8 km/h
Maximum Drive Height	Full Height	Full Height
Capacity (Overall)	227 kg	227 kg
Local Floor Load (With Rated Load)	745 kN/m ²	880 kN/m ²
Overall Floor Load (With Rated Load)	1,040 kg/m ²	1,152 kg/m ²
Maximum # of Persons at 0 m/s wind rating	2	1
Maximum # of Persons up to 12.5 m/s wind rating	1	1 (up to 3.65 m)
Tyre Type	Solid, N/M	Solid, N/M
Tyre Size	12 x 4 x 8	12 x 4 x 8

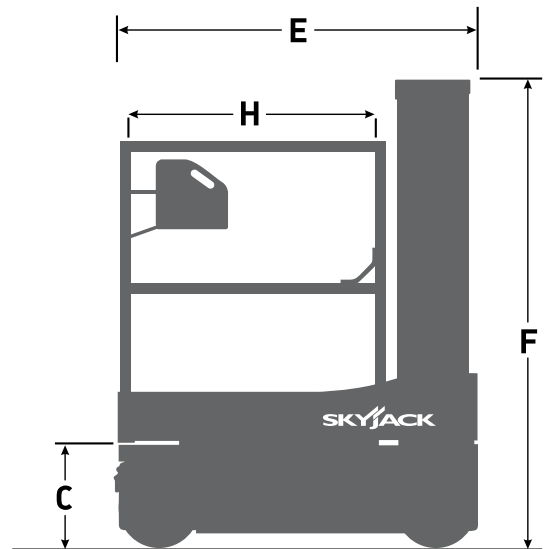
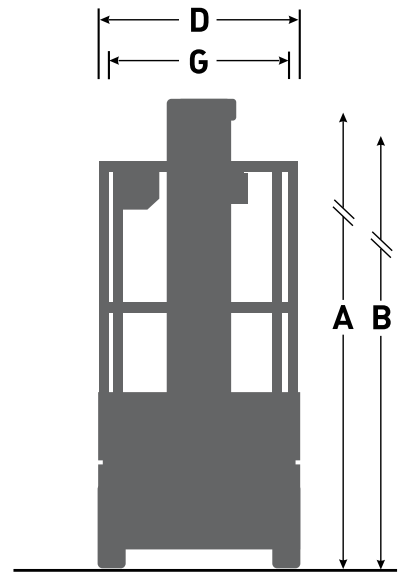

Skyjack Australia Pty Ltd
 Unit 1, 35 Honeycomb Drive
 Eastern Creek
 NSW 2766
 Australia
 Phone +61 (0) 2 9854 0700
 Fax +61 (0) 2 9854 0777
 Email: jcranmer@skyjack.com

www.skyjack.com

SKYJACK
 simply reliable

This brochure is for illustrative purpose only and based on the latest information at the time of printing. Skyjack Inc. reserves the right to make changes at any time, without notice, to specifications, standard and optional equipment. Consult the Operating Maintenance and Parts Manuals for proper procedures. AS marked platforms are in conformance to Standard AS/NZS 1418.10:2011.