

# SJ3215/19

## ELECTRIC SCISSOR LIFTS



### STANDARD FEATURES

- Drivable at full height
- Variable speed, front wheel hydraulic drive
- Dual holding brakes
- SKYCODED™ Colour coded and numbered wiring system
- On-board visual interface with diagnostic capabilities
- Shroud style, impact resistant composite control box with extended cable
- Proportional controls for drive & lift functions
- Tilt sensor (3.5° x 1.5°)
- 0.91 m Roll out extension deck
- 24V DC Power source
- Low voltage battery protection
- 25% Gradeability
- Solid rubber, non-marking tyres
- Pothole protection system
- Wiring for AC outlet at platform
- Tilt alarm with drive & lift cut-out
- All motion audible alarm
- Lanyard attachment points
- Operator horn
- Forklift pockets and tie down/lift lugs
- Overload sensing system
- Solid railings
- Half height spring hinged entry gate
- Telematics ready

### OPTIONS

- Light duty pipe rack
- Heavy duty pipe rack
- Board carrier
- Tool caddy
- Flashing light
- Dual flashing lights
- 250 Ah Batteries
- AGM Batteries
- Lockable swingout trays
- Full height spring hinged entry gate
- Bio oil
- Secondary Guarding Lift Enable (SGLE)
- ELEVATE telematics
- ELEVATE Battery Management System (BMS)\*

† Standard lead times may be increased when optional equipment is added, consult factory.

‡ Capacities and machine weights may differ when options are added.

\* Only available with ELEVATE telematics

# SJ3215/19 ELECTRIC SCISSOR LIFTS

Dimensions	SJ3215	SJ3219
<b>A</b> Work Height	6.57 m	7.79 m
<b>B</b> Raised Platform Height	4.57 m	5.79 m
<b>C</b> Lowered Platform Height	0.91 m	1.04 m
<b>D</b> Overall Width	0.81 m	0.81 m
<b>E</b> Overall Length	1.80 m	1.80 m
<b>F</b> Stowed Height	1.88 m	1.99 m
<b>G</b> Platform Width (Inside Dimension)	0.66 m	0.66 m
<b>H</b> Platform Length (Inside Dimension)	1.55 m	1.55 m
Specifications	SJ3215	SJ3219
Extension Deck (Roll Out)	0.84 m	0.84 m
Ground Clearance (Pothole Raised)	8.9 cm	8.9 cm
Ground Clearance (Pothole Deployed)	2.0 cm	2.0 cm
Wheelbase	1.37 m	1.37 m
Weight	1,148 kg	1,476 kg
Gradeability	25%	25%
Turning Radius (Inside)	0	0
Turning Radius (Outside)	1.65 m	1.65 m
Lift Time (With Rated Load)	17 sec	19 sec
Lower time (With Rated Load)	16 sec	25 sec
Drive Speed (Stowed)	3.4 km/h	3.4 km/h
Drive Speed (Raised)	1.1 km/h	1.1 km/h
Maximum Drive Height	Full Height	Full Height
Capacity (Overall)	272 kg	227 kg
Distributed Capacity (Main Platform)	159 kg	113 kg
Distributed Capacity (Extension Deck)	113 kg	113 kg
Local Floor Load (With Rated Load)	1,093 kN/m <sup>2</sup>	1,159 kN/m <sup>2</sup>
Overall Floor Load (With Rated Load)	991 kg/m <sup>2</sup>	1,188 kg/m <sup>2</sup>
Maximum # of persons at 0 m/s wind rating	2	2
Maximum # of persons up to 12.5 m/s wind rating	1	1
Tyre Type	Solid, N/M	Solid, N/M
Tyre Size	12 x 4 x 8	12 x 4 x 8

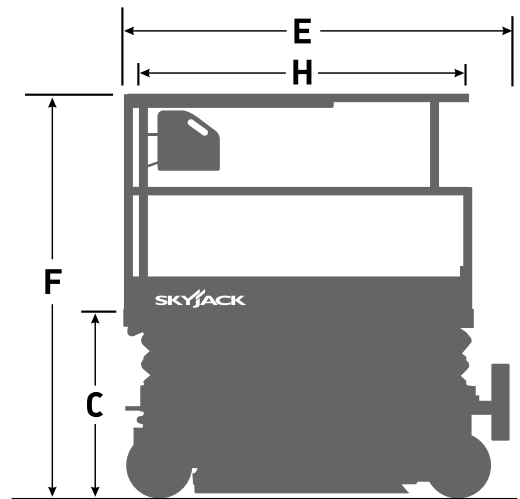
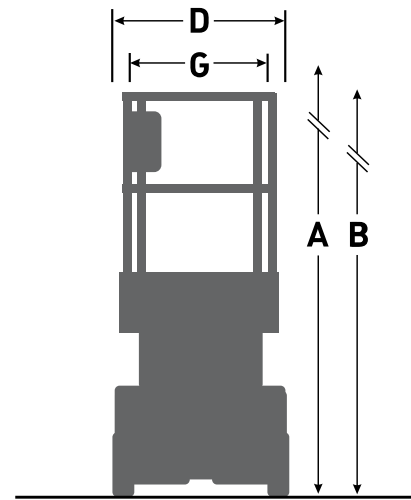

Skyjack Australia Pty Ltd  
 Unit 1, 35 Honeycomb Drive  
 Eastern Creek  
 NSW 2766  
 Australia  
 Phone +61 (0) 2 9854 0700  
 Fax +61 (0) 2 9854 0777  
 Email: jcranmer@skyjack.com

[www.skyjack.com](http://www.skyjack.com)

**SKYJACK**  
 simply reliable