

HYDRAULIC EXCAVATOR

takeuchiTM
From World First to World Leader

TB280FR



Operating Weight: 8,500 kg

Product Features & Specifications

ENGINE

- EU Stage III B / EPA Tier 4 Emission Compliant
- Turbocharged
- DPF Exhaust After Treatment
- Double Element Air Cleaner
- Automatic Deceleration
- Working Modes: Power and High Altitude
- Engine Preheat
- High Capacity Radiator and Hydraulic Oil Cooler
- Automatic Fuel Bleed System
- Engine Safety Start System on the Left Console
- Engine Auto Stop
- Fuel Supply Pump (optional)
- High Capacity Fuel Filters

ELECTRICAL

- 5.7" Color Multi-Informational Display
- Sealed Rocker Switches
- 12 volt System with 80 amp Alternator
- 1 Working Light on Boom
- 2 Cab Front Lights (optional)
- 2 Cab Rear Lights (optional)
- Beacon Socket and Lamp Switch
- TSS (Takeuchi Security System; Immobilizer) (optional)
- Travel Alarm (optional)
- Horn

OPERATOR'S STATION

- ROPS / OPG Level I
- Deluxe High Back Suspension Seat
- Head Rest (optional)
- 2" Retractable Seat Belt
- Cab with Heat Defrost, Windshield Wiper and Washer, Skylight with Sunshade, AM / FM / MP3 Bluetooth Radio, 12v Power Outlet
- Rain Guard (optional)
- OPG Level II Roof Guard Kit (optional)
- Air Conditioner (optional)

UNDERCARRIAGE AND FRAME

- Triple Flanged Track Rollers
- 2-Speed Travel with Automatic Shift
- High Torque Planetary Final Drive
- Auto Track Tensioning
- Large Wraparound Counterweight
- 2" Retractable Seat Belt
- 450 mm Rubber Crawlers
- 450 mm Steel Crawlers (optional)
- 450 mm Segmented Rubber Crawlers (optional)
- Rubber Pads for 450 mm Steel Crawlers (optional)
- Heavy Duty Dozer Blade with Float (optional)

HYDRAULIC

- Variable Displacement Pump
- Straight Travel Circuit
- Hydraulic Joystick Controls
- Proportional Control for Service Port 1
- Detent for Service Port 1
- Proportional Control for Service Port 2
- Service Port 3 for Quick Hitch (optional)
- Proportional Control for Service Port 4 (optional)
- Adjustable Auxiliary Flow for Service Port 1, 2, and 4
- Hydraulic Selector Valve (1-way / 2-way)
- Auto Pressure Release (optional)
- Air Breather, Hydraulic Tank
- Auto Tank (optional)
- Pilot Accumulator

WORKING EQUIPMENT

- Full Rotation Capability and Patented STS Boom
- Cushioned Boom, Arm, and Offset Cylinders
- Main Boom Cylinder Guard
- Auxiliary Hydraulic Circuit Plumbed to Arm
- 1,650 mm Arm
- 1,810 mm Arm (optional)
- 2,000 mm Arm (optional)
- Boom Holding Valve with Lift Alarm
- Arm Holding Valve (optional)
- Pattern Change Valve (ISO or G) (optional)

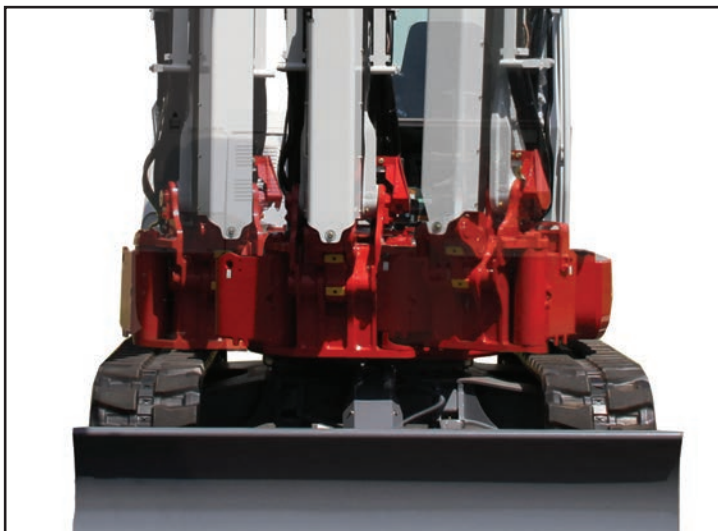

Side to Side Boom Design



Automotive Styled Interior

TOUGH, POWERFUL, RELIABLE



Large Floor with Foot Rest



Wraparound Counterweight



Triple Flanged Track Rollers



Optional Work Lights

The TB280FR is a unique platform that separates itself from the competition with its unique side-to-side (STS) boom configuration and full rotation (FR) capabilities. One of the greatest benefits of the STS boom is the unmatched visibility to the attachment and job site. This design also allows the boom to be stowed over center in the full upright position enabling it to make a full rotation (FR) within a very tight radius allowing it to work within similar confines

as a smaller 5 ton machine for greater performance and productivity. Additional features include an updated cabin with automotive styled interior, color multi-informational display, multiple attachment presets with operator adjustable flow rates, standard auxiliary hydraulic circuits 1 & 2 allowing the operator to run a wide range of attachments, backfill blade and a tilt-up cab for greater serviceability.



A tilt-able cabin and large lockable service hoods provide outstanding maintenance access.

OPERATING PERFORMANCE

Operating Weight - Cab (Rubber)	8,500 kg
Operating Weight - Cab (Steel)	8,695 kg
Bucket Capacity (Heaped)	0.245 m ³
Slew Speed	10.0 min-1
Travel Speed	
1st	2.7 km/h
2nd	5.2 km/h
Gradeability	30°
Ground Pressure - Cab (Rubber)	37.9 kPa
Ground Pressure - Cab (Steel)	39.3 kPa
Maximum Bucket Breakout Force	46.7 kN
Maximum Arm Digging Force	32.9 kN
Traction Force	88.0 kN
Boom Swing Angle (Left/Right)	30° / 15°

ENGINE

Model	Yanmar / 4TNV98CT
Rated Output (ISO 14396)	51.6 kW / 2,000 min-1
Maximum Torque	308 Nm / 1,300 min-1
Displacement	3,318 ml
Alternator	12 V - 0.96 kW
Battery (IEC 60095-1)	12 V - 90 A·h

FLUID CAPACITY

Engine Lubrication	9.4 L
Cooling System	14.0 L
Fuel Tank Capacity	100.0 L
Hydraulic Reservoir Capacity	71.0 L
Hydraulic System Capacity	120.0 L

HYDRAULIC SYSTEM

P1, P2	Variable Displacement Pump
Flow Rate	74.0 L/min
Relief Pressure	27.5 MPa
P3	Gear Pump
Flow Rate	59.0 L/min
Relief Pressure	24.0 MPa
Service Port 1	
Flow Rate	148.0 L/min
Hydraulic Pressure	20.6 MPa
Service Port 2	
Flow Rate	59.0 L/min
Hydraulic Pressure	20.6 MPa
Service Port 3	
Hydraulic Pressure	20.6 MPa
Service Port 4	
Flow Rate	59.0 L/min
Hydraulic Pressure	20.6 MPa

SAFETY and HEALTH

Vibration Levels	
Hand / Arm	≤ 2.5 m/s ²
Body	≤ 0.5 m/s ²
Noise Level	
Sound Power Level	Lwa 99 dB



Multi-Informational Display



Unmatched Visibility



Dozer Blade



Multi-Function Switch Bank

TB280FR Hydraulic Excavator

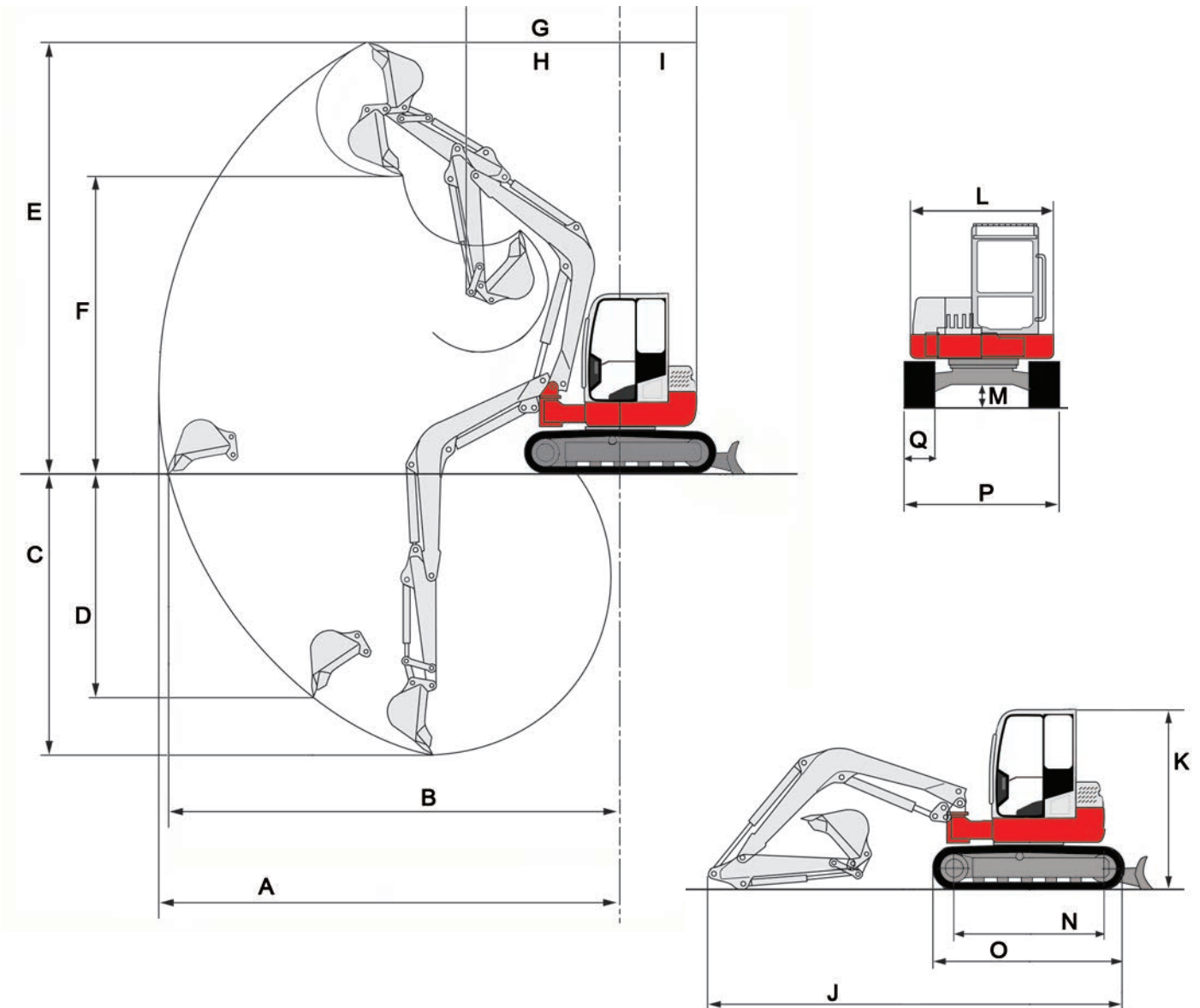

MACHINE DIMENSIONS	1,650 mm ARM	1,810 mm ARM	2,000 mm ARM
A Maximum Reach	6,870 mm	7,035 mm	7,195 mm
B Maximum Reach at Ground Level	6,715 mm	6,885 mm	7,045 mm
C Maximum Digging Depth	4,195 mm	4,375 mm	4,540 mm
D Maximum Vertical Digging Depth	3,160 mm	3,330 mm	3,495 mm
E Maximum Height of Cutting Edge	6,280 mm	6,375 mm	6,465 mm
F Maximum Dumping Height	4,295 mm	4,390 mm	4,480 mm
G Front Swing Radius	2,835 mm	2,880 mm	2,880 mm
H Front Swing Radius with Boom Offset	1,610 mm	1,610 mm	1,610 mm
I Slew Radius	1,280 mm	1,280 mm	1,280 mm
J Overall Length	6,160 mm	6,175 mm	6,285 mm
K Overall Height	2,725 mm	2,725 mm	2,725 mm
L Upper Structure Overall Width	2,170 mm	2,170 mm	2,170 mm
M Ground Clearance	315 mm	315 mm	315 mm
N Crawler Base	2,210 mm	2,210 mm	2,210 mm
O Crawler Overall Length	2,855 mm	2,855 mm	2,855 mm
P Crawler Overall Width	2,300 mm	2,300 mm	2,300 mm
Q Crawler Shoe Width	450 mm	450 mm	450 mm



© 2018 Takeuchi MFG. Co., Ltd. All Rights Reserved. In accordance with our established policy of continued improvement, specifications and features are subject to change without notice. Pictures may show options other than standard equipment.

FORM: TB280FR Compact Excavator Spec Sheet - Feb. 2018

TAKEUCHI[™]
From World First to World Leader