

TAKEUCHI

From World First to World Leader

TL12V-2 TRACK LOADER



TOUGH, POWERFUL, RELIABLE



Pilot Operated Controls



Battery Access Panel



Lower Cross Member



Oversized Lift Cylinders

Takeuchi's first vertical lift compact track loader, the TL12V-2 demonstrates a continuous commitment to product improvement and innovation. It is the largest and most capable track loader available today and delivers best in class rated operating capacity (ROC), a completely redesigned operator's station that features a color multi-information display with rear camera, convenient rocker switches to control a wide range of functions, and an updated undercarriage design that enhances operator comfort by reducing vibration and noise levels.

The TL12V-2 features a powerful 81.8 kW U.S. EPA Final Tier 4 / EU Stage IV emissions compliant engine

while delivering outstanding power and torque for the very best performance in the most demanding applications.

Performance features include massive loader arms, oversized lift cylinders and pins, rear bumper with integrated tie downs, high capacity cooling module, and LED lights on the front and rear of the machine. The TL12V-2's interior includes an updated overhead door design, redesigned foot throttle, precision pilot controls, backlit rocker switches, convenient cup holders, and a deluxe high back suspension seat for those long hours on the jobsite.



Spacious Operator's Station with Easy to Reach Controls and Switches

Product Features & Specifications

ENGINE

- U.S. EPA Final Tier 4 / EU Stage IV Emission Compliant
- Turbocharged and Intercooled
- DOC+DPF+SCR Exhaust After Treatment
- Active Power Control Power Management System
- Selectable Work Modes - Power and ECO
- Dial Throttle Control
- Automatic Fuel Bleed System
- Extended Life Coolant
- High Capacity Radiator, Hydraulic Oil Cooler and Inter-cooler Mounted Side-by-Side on Swing Out Frame
- Double Element Air Filter

ELECTRICAL

- 12 volt System with 90 amp Alternator
- Heavy Duty, Quick Access Battery
- LED Work Lights, Front and Rear
- 5.7" Color Multi-Informational Display with Rear Camera
- Sealed Rocker Switches
- Back-up Alarm
- Horn

UNDERCARRIAGE AND FRAME

- Quiet Track Design with Flotation Tread
- Long Track Frame
- Fully Welded Frame with Integrated Cross Members
- Rear Bumper Integrated into Frame
- Front and Rear Tie-Down and Lift Points
- Permanently Sealed Track Rollers with Metal Face Seals
- Double Reduction Planetary Track Drives
- Two-Speed Travel

HYDRAULIC AND WORKING EQUIPMENT

- High Lift Vertical Arm Design
- Cushioned Arm Cylinders
- Arm Float with Detent
- Hydraulic Pilot Controls
- Proportional Auxiliary Controls with Detent
- Pressure Relieving Flat Faced Coupler Body
- Hydraulic Self Leveling (ON/OFF)
- Mechanical Quick Coupler
- Easy Access Grease Points
- Lower Front Cross Member
- Fuel / DEF Fill with Alarm
- 14-Pin Connector with Push Button Control (optional)
- Hydraulic Quick Coupler (optional)
- High Flow Auxiliary Hydraulics 153.0 Lpm (optional)
- Secondary Auxiliary Circuit (optional)
- Ride Control (optional)
- Control Pattern Change Valve (ISO or H) (optional)

OPERATOR'S STATION

- Deluxe High Back Adjustable Suspension Seat
- Rear Pivoting Seat Bar with Integrated Arm Rests
- Retractable 2" Seat Belt
- ROPS/FOPS Structure
- FOPS Level 2 Roof Guard (optional)
- Polycarbonate Front Door (optional)
- Pressurized Cab with Roll-up Door, Air Conditioning, Heat, Defrost, Front/Rear Wiper and AM/FM/MP3 Radio (Cab Only)
- 3 Point Seat Belt (optional)



Convenient Service and Maintenance Access



Vertical Lift Path for Balance and Stability

OPERATING PERFORMANCE

Operating Weight - Canopy	5,765 kg
Cab	5,915 kg
Tipping Load	5,325 kg
Rated Operating Capacity (ISO 14397-1) @ 35%*	1,865 kg
Operating Load @ 50% of Tip Load	2,660 kg
Bucket Breakout Force	35.0 kN
Lift Arm Breakout Force	31.6 kN
Traction Force	62.3 kN
Ground Pressure - Canopy	33.0 kPa
Cab	33.9 kPa
Travel Speed - Low	8.1 km / h
High	11.8 km / h

*Rated Operating Capacity for compact track loaders is rated according to ISO 14397-1 at no more than 35% of the tipping load.

HYDRAULIC SYSTEM

Auxiliary Flow - Primary Circuit	88.0 L / min
Auxiliary Flow - High Flow (optional)	153.0 L / min
Auxiliary Flow - 2nd Circuit (optional)	88.0 L / min
Hydraulic System Pressure	24.0 MPa

ENGINE

Model	Kubota / V3800-TIEF4B
Emission Standard	U.S. EPA Final Tier 4 EU Stage IV
Engine Displacement	3,769 ml
Engine Output	81.8 kW / 2400min-1
Maximum Torque	379.3 Nm / 1500min-1

FLUID CAPACITIES

Engine Lubrication	13.2 L
Cooling System	18.0 L
Diesel Exhaust Fluid (DEF)	18.0 L
Fuel Tank Capacity	119.5 L
Hydraulic Reservoir Capacity	50.0 L
Hydraulic System Capacity	94.0 L



5.7" Color Display with Rear Camera



Rear Camera



LED Work Lights



Rocker Switches

TL12V-2 TRACK LOADER

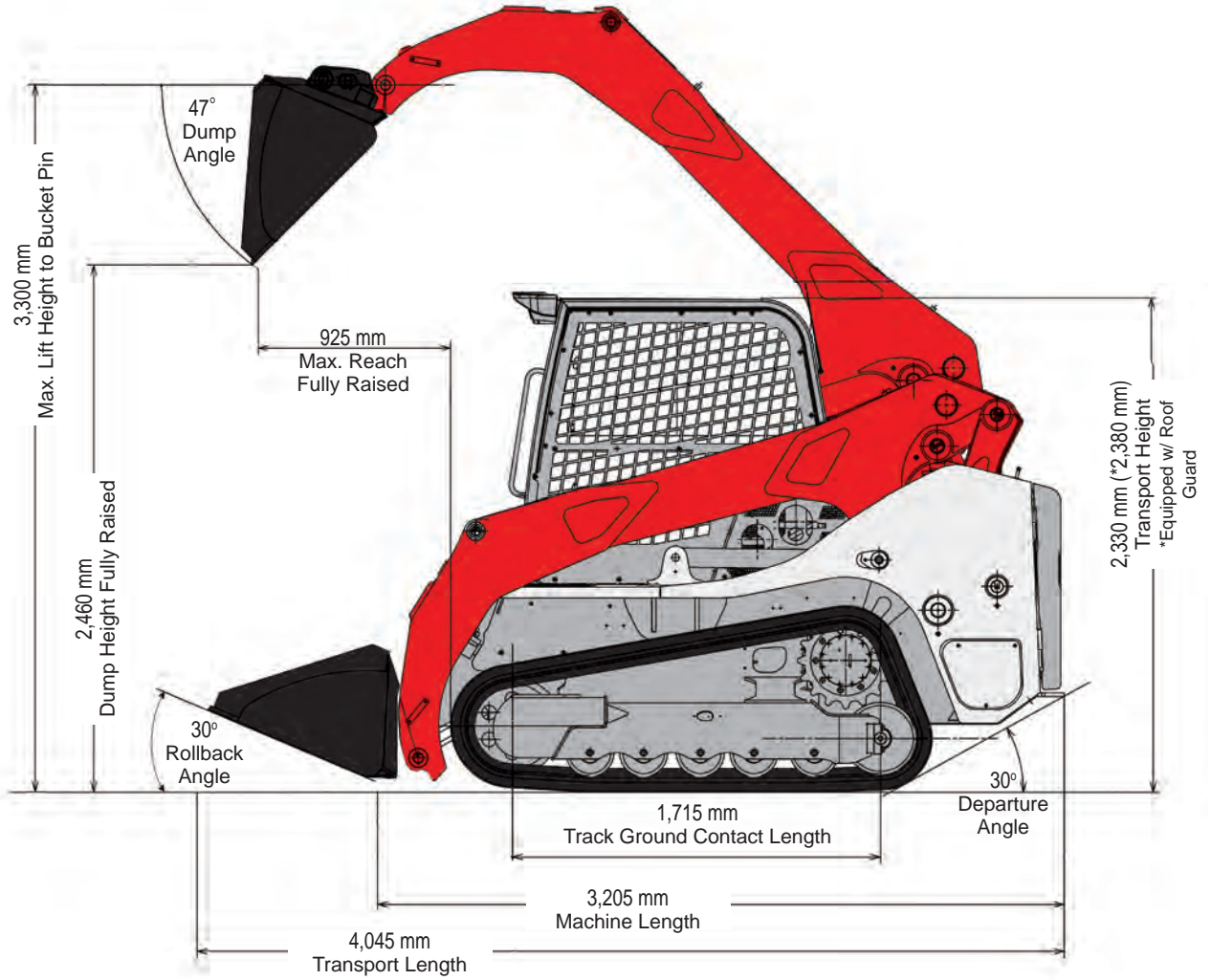

2,505 mm Clearance Circle with HO Bucket

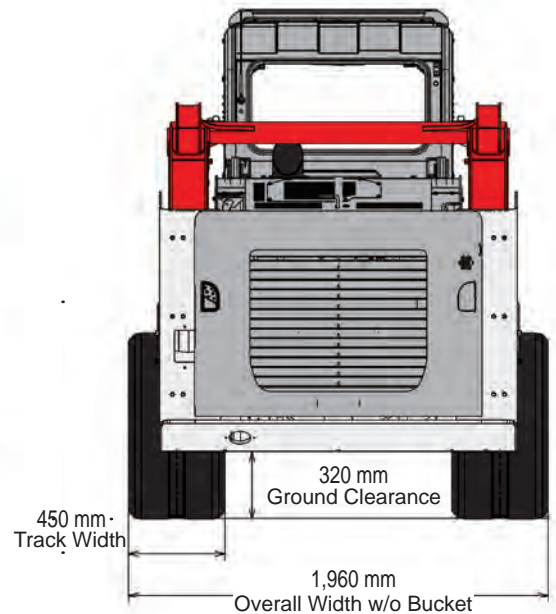
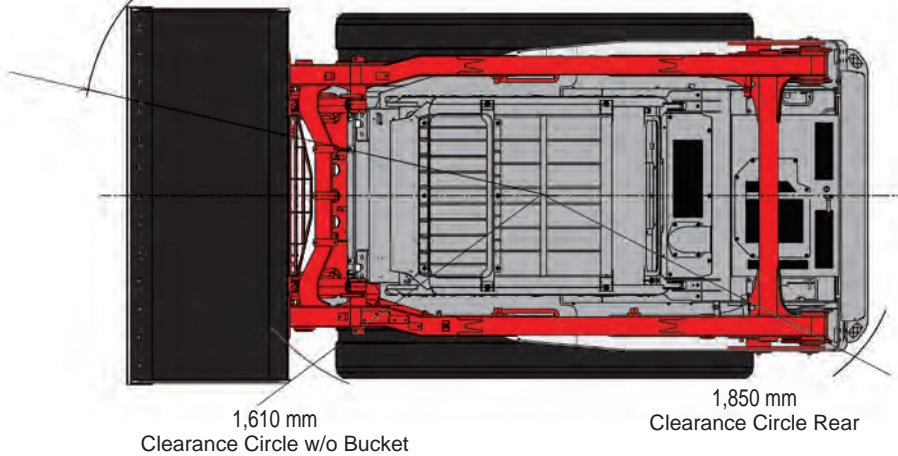



TAKEUCHI
From World First to World Leader